

# ABLOY® CONCEALED PRODUCTS

*Prefers the aesthetic advantages*



# ABLOY® DOOR CLOSERS



## *Superior performance and reliability*

**ABLOY®** high security products are known and highly respected all over the world. Every item in our wide product range represents top quality and superior performance.

**ABLOY®** door closers protect door constructions by controlling the opening and closing actions of the door. Reliable performance over a wide operational temperature range guarantees that energy will be saved and security increased.

Production of **ABLOY®** door closers started in the 1930s. Today, we provide high quality and advanced technology in our production facilities.

Our long extensive experience and expertise combined with customer-oriented research and development mean that we have a wide range of solutions for the varying demands of different door environments.

Our global network of sales offices and distributors will help you to choose right products to increase security and convenience in your specific application. The functions, features, and wide variety of installation alternatives offered by **ABLOY®** door closers give you convenient operation, simplified installation and ease of adjustment and maintenance.



# ABLOY® OPERATION OF CONCEALED DOOR CLOSERS



## CONTENT

Operation of concealed door closers	3
<b>ABLOY® DC840</b>	4
<b>ABLOY® DC860</b>	5
<b>ABLOY® Accessories for door closers</b>	6
Operation of concealed fire door closing systems	7
<b>ABLOY® FD480</b> Electromechanical hold-open device	8
<b>ABLOY® FD481</b> Mechanical door coordinator for double doors	8
<b>ABLOY® FD482</b> For double doors with coordinator and two electromechanical hold-open devices	9
<b>ABLOY® FD484</b> For double doors with coordinator and electromechanical hold-open devices	9
<b>ABLOY® FD480 - FD484</b> installation	10
<b>ABLOY® Accessories for fire door closing systems</b>	11

## OPERATION

The operation of the door closers is based on a hydraulically controlled CAM-action mechanism. Inside the closer oil is used to control the closing and latching speeds. The adjustable valves enable the adjustment of the speeds and features.

Opening a door, the spring inside the closer is becoming tense. When the door is released, the potential of the spring pushes the piston back and the door closes. Pressure relief valve is the standard feature to protect the door from abuse and ensure reliable operation in demanding conditions.

## CONCEALED DOOR CLOSER

Door closer and rail system are mounted inside the door leaf and frame. When the door is open the only visible part is arm. After installation it is easy to adjust the closing force as well as closing and latching speed. Non-handed closer and arm system enable the use of the same products in left and right handed doors.

## ADJUSTABLE CLOSING FORCE

**ABLOY® DC840** and **DC860** door closers are equipped with adjustable spring power which ensures presetting of the spring.

Due to adjustable spring power, the same door closer can be used in various applications

## ADJUSTMENT (C- AND L-VALVE)

Closing speed (Valve C):

The closing speed can be adjusted 120-7 degrees.

Latching speed (Valve L):

The latching speed can be adjusted 7-0 degrees.

## MECHANICAL BACK CHECK

A brake affects door movement from 80 degrees to fully open and protects the door by preventing it from being pulled open by the wind.

# ABLOY® DC840

*“Non handed cam action concealed door closer for heavy duty use”*

Thanks to the cam construction it is extremely light to open but strong enough to close the door in every situation. **ABLOY®** DC840 can be adjusted to meet the requirements of the light opening resistance for example the DDA (Disability Discrimination Act) in UK. **ABLOY®** DC840 is suitable for 40 mm doors, internal and fire doors. For use with **ABLOY®** FD480 series fire door closing systems.



## FEATURES

- CE certified
- Adjustable closing force size EN 1-4
- Separate adjusting valves for closing and latching speed, mechanical BC
- Pressure relief valve to protect against abuse
- Wide operating temperature range: -15...45°C
- Anodized aluminium door closer body
- Two different arm systems: DC892, DC893

## ADJUSTMENT

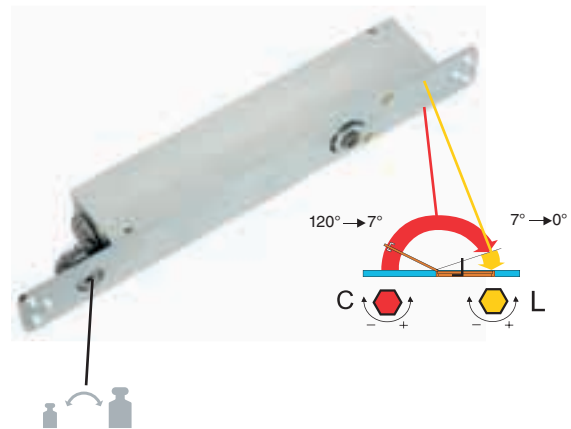

## INSTALLATION AND DIMENSIONS

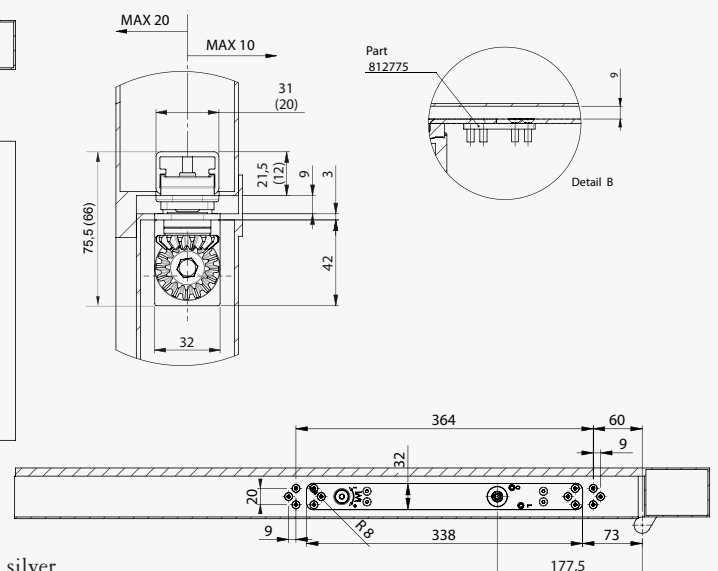
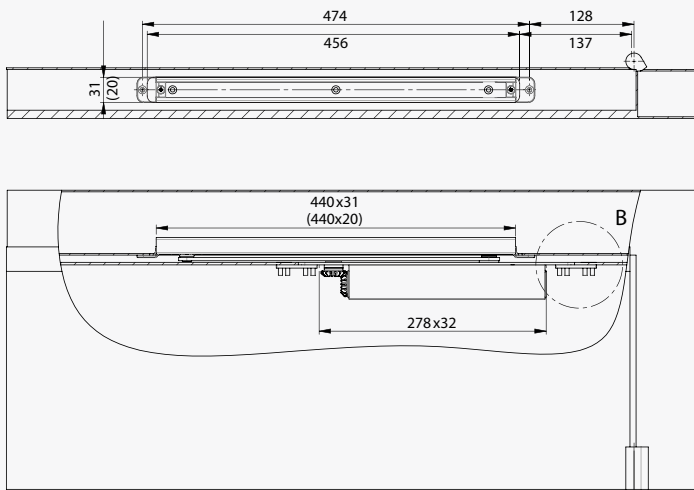

Dimensions for DC893  
 Dimensions shown in ( ) = DC892  
 When ordering, please specify

- Door closer model e.g. DC840, quantity, arm type and colour e.g. DC892 silver.
- The arm is not included in the delivery or price of the door closer.



# ABLOY® DC860

*“Concealed door closer for demanding applications”*

**ABLOY® DC860** is non-handed cam action door closer and therefore very easy to install. Thanks to the cam construction it is extremely light to open but strong enough to close heavy doors. **ABLOY® DC860** is suitable for external and internal doors and heavy duty doors. For use with **ABLOY® FD480** series fire door closing systems.



## FEATURES

- CE certified
- Adjustable closing force size EN 1-5
- Separate adjusting valves for closing and latching speed, mechanical BC
- Pressure relief valve to protect against abuse
- Wide operating temperature range: -15...45°C
- Anodized aluminium door closer body
- Two different arm systems: DC892, DC893

## ADJUSTMENT

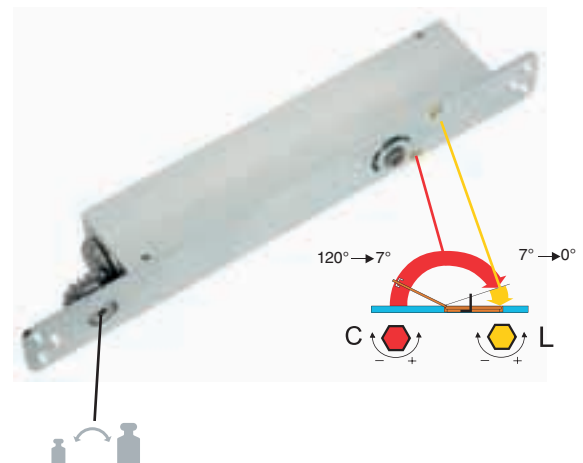

## INSTALLATION AND DIMENSIONS

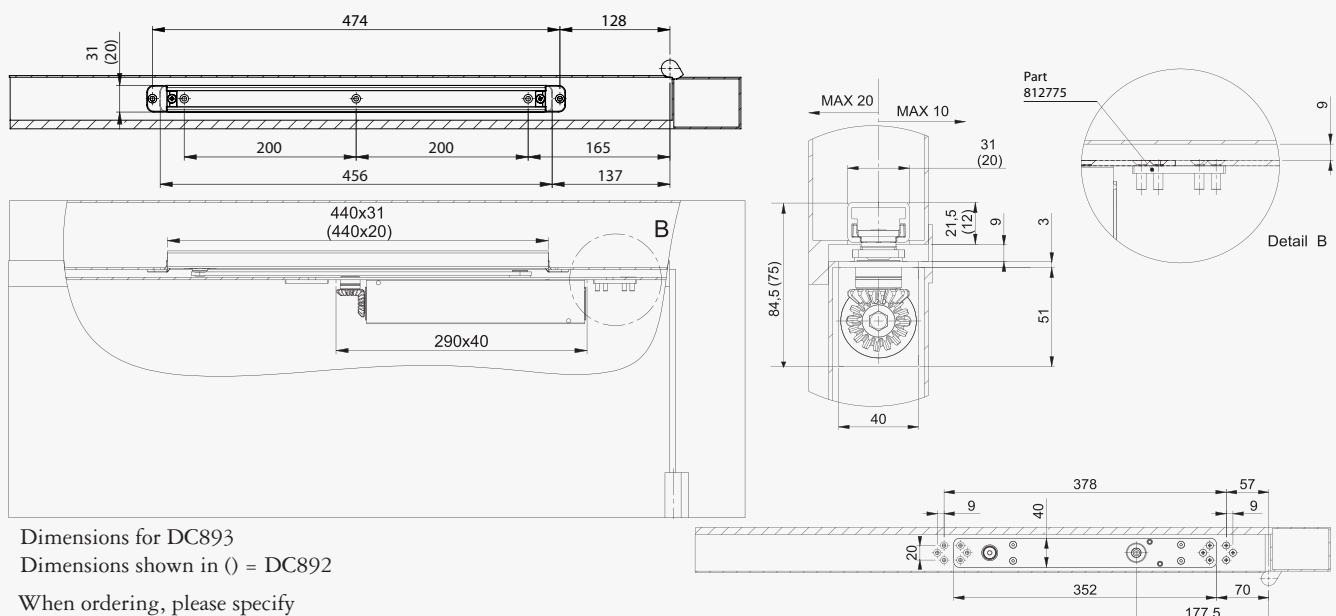

Dimensions for DC893

Dimensions shown in ( ) = DC892

When ordering, please specify

- Door closer model e.g. DC860, quantity, arm type and colour e.g. DC892 silver.
- The arm is not included in the delivery or price of the door closer.

# ABLOY® ACCESSORIES FOR DOOR CLOSERS



## SLIDING ARMS



Sliding arm **ABLOY®** DC892

Measurements:

440 mm (L) x 20 mm (W) x 12 mm (H)

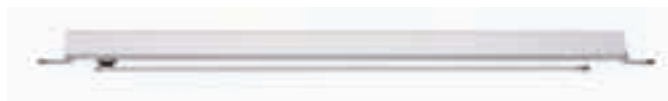

Sliding arm **ABLOY®** DC893

Measurements:

440 mm (L) x 31 mm (W) x 21. mm (H)

## HOLD-OPEN DEVICE AND OPENING DAMPER



Hold-open device **ABLOY®** DC152

- Adjustable hold-open force
- Max. hold-open angle ~110°
- Can be used only with DC893

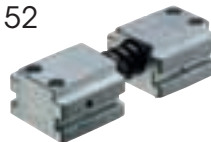

Opening damper **ABLOY®** DC153

- Max. damping angle ~ 110°
- Designed to brake the door before hitting the door stopper
- Does not replace the mechanical door stopper
- Can be used only with DC893



**ABLOY®** 812775 mounting plates

- Can be used with DC840 and DC860 door closer
- To be used in profile doors.



Opening damper **ABLOY®** DC157

- Max damping angle ~ 110°
- Designed to brake the door before hitting the door stopper
- Does not replace the mechanical door stopper
- Can be used only with DC892

## RECOMMENDED DOOR SIZES ACCORDING EN1154

Door Closer Size	Recommended max. door leaf width mm	Door leaf mass Kg
EN1	750	20
EN2	850	40
EN3	950	60
EN4	1100	80
EN5	1250	100
EN6	1400	120
EN7	1600	160



## *Easy access and convenience*

It is vital for fire doors to close in the event of fire. The fire door must close and latch automatically in order to limit the spread of smoke and fire into other parts of the building. During daytime the normal use of fire doors requires the doors to remain open.

**ABLOY®** fire door closing systems guarantee easy access and convenience for use in the day time as well as maximum security in the event of fire. **ABLOY®** fire door closing systems are composed of reliable and compatible components that enable building up a safe, individual solution for each application.

## FUNCTION OF FIRE DOOR CLOSING SYSTEMS

If fire doors are held open they must close in the break out of a fire to retain smoke and flames and prevent the fire from spreading throughout the building. The smoke detector (1) reacts to smoke and activates the alarm to the hold open device of the door (2). The door closer (3) closes and latches the door into closed position. The fire alarm central panel or the fire detector (in a single door system) can activate the alarm.

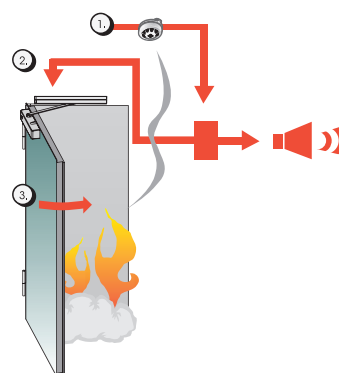

When ordering, please specify

- Product number (including arm and sliding rail) and colour for the fire door closing system (including arm and sliding rail) e.g. FD481 silver
- Product number for the door closer e.g. DC860



# ABLOY® CONCEALED FIRE DOOR CLOSING SYSTEMS

*“Designed for places that require  
aesthetic and flexible use”*



## **ABLOY® FD480** ELECTROMECHANICAL HOLD-OPEN DEVICE FOR SINGLE DOOR

FD480 is applicable for places, where fire doors are constantly kept open. Applications for FD480 are hotels, office buildings and fire doors where hold open function is needed. The maximum door width is 1400 mm.

Fire door is held open by FD480 at the selected angle. When power is switched off, e.g. when smoke detectors react to smoke, the door closes. The hold open angle for the door can be adjusted from 70° to 120°. Hold-open device has adjustable hold-open function. Current consumption 1 x 60 mA (24 VDC).

## **ABLOY® FD481** MECHANICAL DOOR COORDINATOR FOR DOUBLE DOORS

FD481 is useful in applications where doors are normally kept closed and the active door is used as a passage door. FD481 is designed for double doors with hinge distance 1350 - 2800 mm.

FD481 mechanical coordinator keeps the active door open when inactive door is open. Active door starts to close when the inactive door is almost closed. After active door is closed it latches the inactive door.

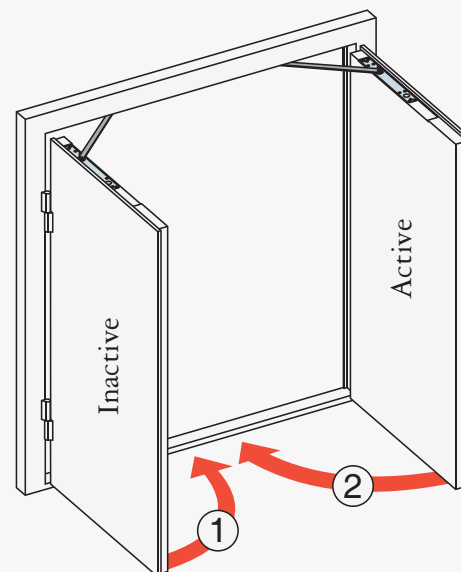
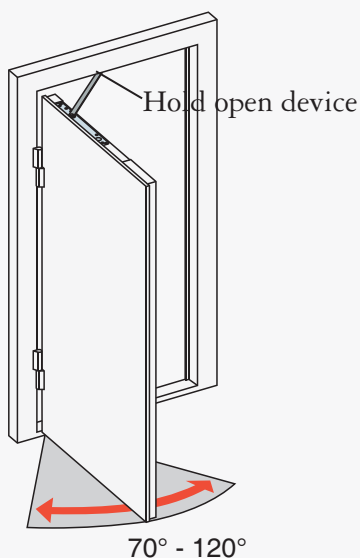



# ABLOY® CONCEALED FIRE DOOR CLOSING SYSTEMS

*“Advanced fire door closing systems for double doors”*

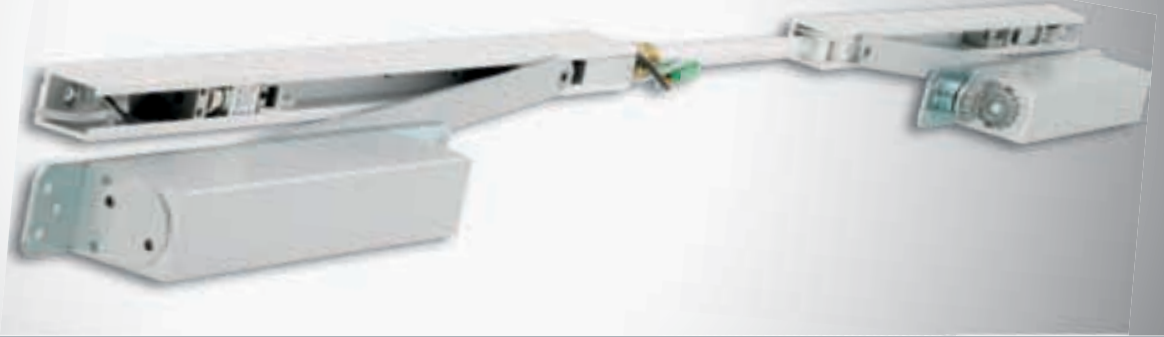

## ABLOY® FD482 FOR DOUBLE DOORS WITH COORDINATOR AND TWO ELECTROMECHANICAL HOLD-OPEN DEVICES

FD482 is designed for places that requires flexible use. Two hold-open devices provide possibility to keep either only the active door or both door leaves open. FD482 is designed for double doors with hinge distance 1350-2800 mm.

The doors are held open by the hold-open devices at the selected angle. When the power is switched off, e.g. when the smoke detectors react to smoke, the inactive door closes first and when it is almost closed, the active door starts to close. Hold-open angle for both doors can be adjusted from 70° to 120°. Current consumption 2 x 60 mA (24 VDC).

## ABLOY® FD484 FOR DOUBLE DOORS WITH COORDINATOR AND ELECTROMECHANICAL HOLD-OPEN DEVICE

FD484 is designed for example hotels and hospital corridors, where both door leaves are usually kept open. FD484 is designed for double doors with hinge distance 1350-2800 mm.

In normal day use both doors are open. The hold open angle for inactive door can be adjusted from 70° to 120°. The hold-open device keeps the inactive door open whereas the coordinator keeps the active door open. When the power is switched off, e.g. when the smoke detectors react to smoke, the inactive door closes first and when it is almost closed, the active door starts to close. Hold-open device include adjustable hold-open force. Current consumption 1 x 60 mA (24 VDC).

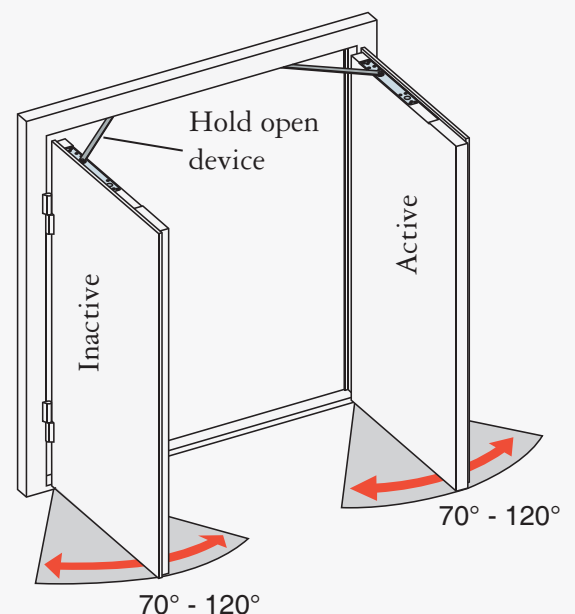
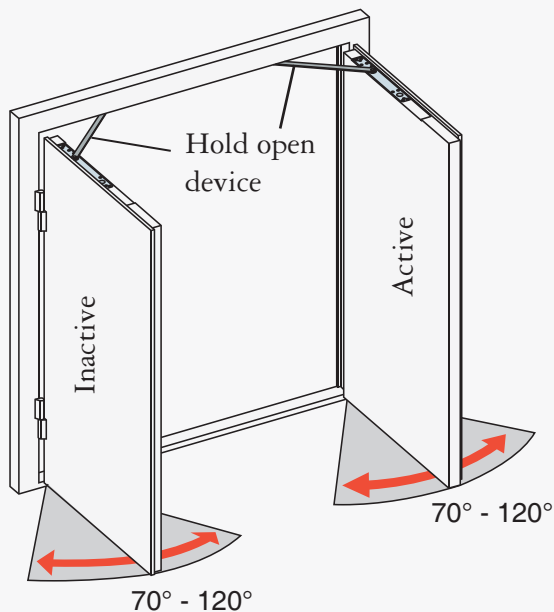

# ABLOY® FD480 - FD484 + DC840, DC860 INSTALLATION

## INSTALLATION AND DIMENSIONS

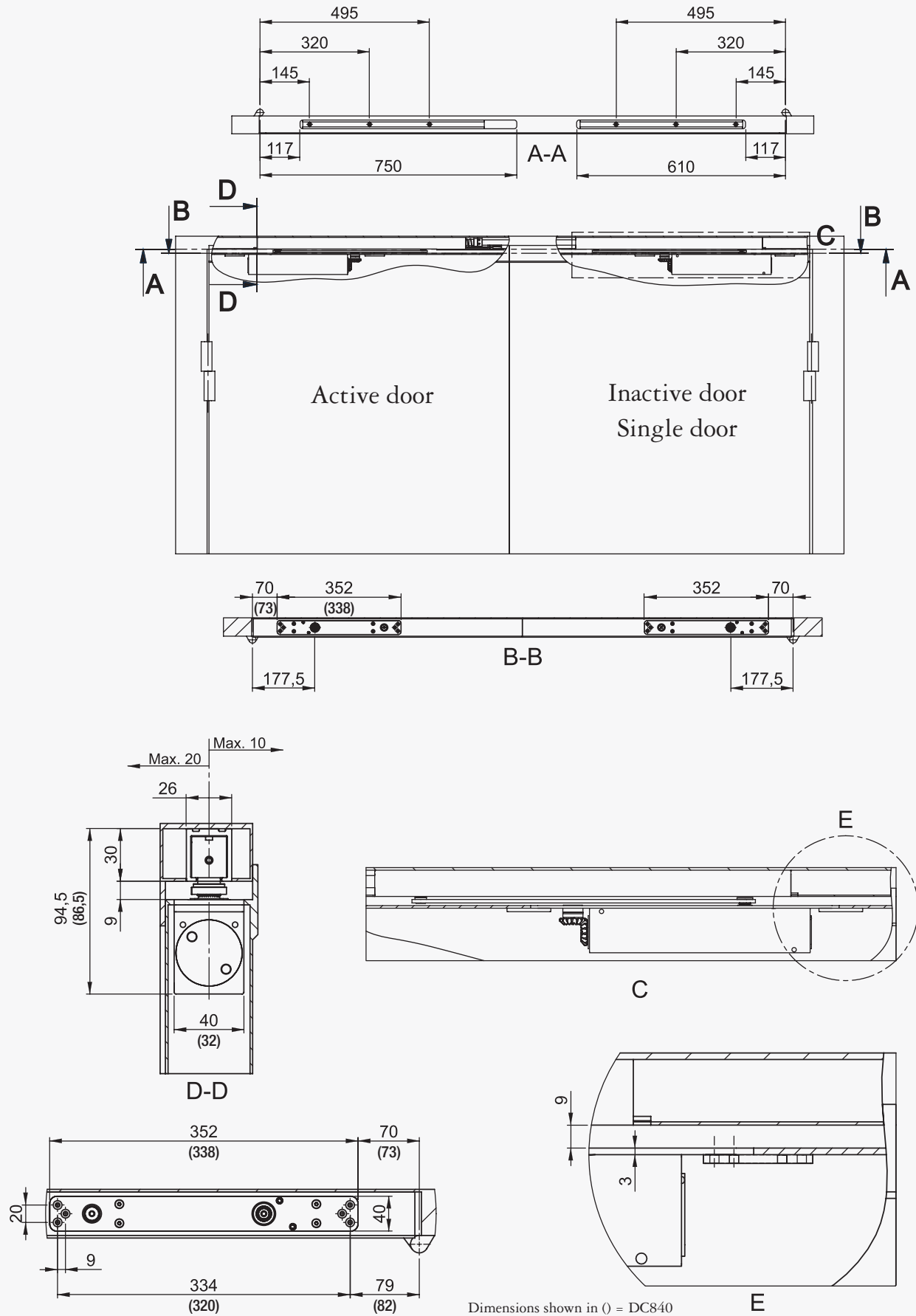

# ABLOY® ACCESSORIES FOR FIRE DOOR CLOSING SYSTEMS

## ACCESSORIES



Control unit **ABLOY® 7400**

- Supply voltage 230 VAC
- Output voltage 24VDC
- Max. output current 300 mA



Battery back-up **ABLOY® 7404**

- Capacity 0,7 Ah



Smoke detector  
**ABLOY® FD600** (optical)  
**ABLOY® FD602** (heat)

- Operating voltage 15-30 VDC
- Maximum current 30 mA



**ABLOY® EA701**

- Power supply 230 AC
- Output voltage 24VDC
- Max. current 2,5 A



Wall magnets **ABLOY® 7438, 7439**

- Operating voltage 24VDC
- Normal current 16mA
- Hold open force 500 N



Automatic flush bolt  
**ABLOY® FD108**

- Used in double door systems for locking the passive door leaf



Door release buttons  
**ABLOY® 7462** (surface)  
**ABLOY® 7463** (mortice)

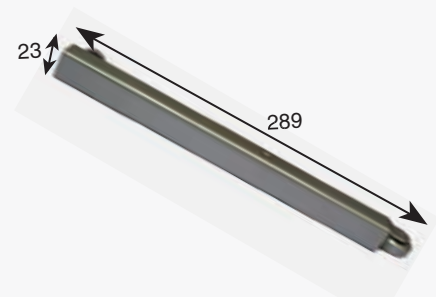

Carry bar **ABLOY® FD101**

- Enables the correct closing sequence of the doors



**ABLOY®** is a registered trademark of Abloy Oy, one of the leading manufacturers of locks, locking systems and architectural hardware and the world's leading developer of products in the field of electromechanical lock technology.

The unique **ABLOY®** detainer disc cylinder mechanism has several advantages over conventional locking mechanisms. Ever since its invention in 1907, it has been a symbol of high security and superior performance.

Our range consists of electromechanical locks, cam locks, padlocks, office furniture locks, rim locks, lock cases, cylinders for different types of mortice locks, door closers, door automatics and architectural hardware. **ABLOY®** locking solutions for every application are available from our world-wide network of distributors.

Customer-oriented development, combined with our long experience and extensive security expertise, mean that **ABLOY®** security solutions employ the very latest technology to meet your needs.



[www.abloy.com](http://www.abloy.com)

Abloy Oy  
Wahlforssinkatu 20  
P.O.Box 108  
FI-80101 JOENSUU  
FINLAND  
Tel. +358 20 599 2501  
Fax +358 20 599 2209

